

LK Minishunt M60n

DESIGN

LK Minishunt M60n is a shunt group intended for use when smaller underfloor heating areas are to be connected to an existing heating system. LK Minishunt M60n adapts the heating system temperature to the lower temperature necessary for the underfloor heating system. Its capacity can normally be set at a heating need of 50 W/m² to a maximum 60 m² underfloor heating area. Capacity is however dependent on primary temperature, pressure, laying method etc.

- For underfloor heating areas up to 60 m².
- Compact design.
- Energy efficient circulation pump.
- Thermostat-controlled maximum limit of supply temperature.
- Switchable between single or twin pipe systems.
- VF valve.
- Easy filling & air bleeding.
- Expandable to 2, 3 or 4 underfloor heating circuits.

SUPPLIED WITH PRODUCT

- Circulation pump Wilo Para RSB/6-43/SC, with automatic speed control.
- Thermostat with capillary tube sensor, length 2 m.
- Thermometer to place in one of the shunt group's thermometer pockets.
- Hose 0.5 m for air bleeding.
- Primary connector ¾" EuroCone and 2 connectors for CU15.
- Bracket.

ACCESSORIES

- Accessories for the primary connector include connectors for CU12 mm and PEX-/PAL pipes dim. 16x2, 20x2 and 20x2.8.
- The LK Elbow Pipes M60n for connecting the primary connector when the feed pipe is from below or above. The elbow pipes enables compact assembly.
- Connection couplings for underfloor heating pipes dim. 8, 12, 16 and 20 mm.
- The LK Mini Manifold for 2, 3 or 4 underfloor heating circuits.
- Installation cabinets for built-in or wall mounting, see heading *Installation cabinets*.
- The LK Heater 350 is an electric comfort heater for underfloor heating installations using the LK Minishunt M60n. The electric heating cartridge output is 350W and is sufficient under normal conditions for underfloor heated areas up to 12 m².

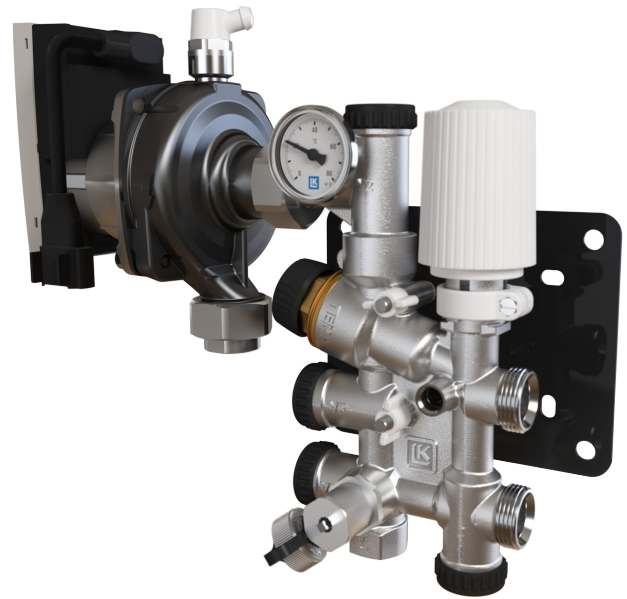
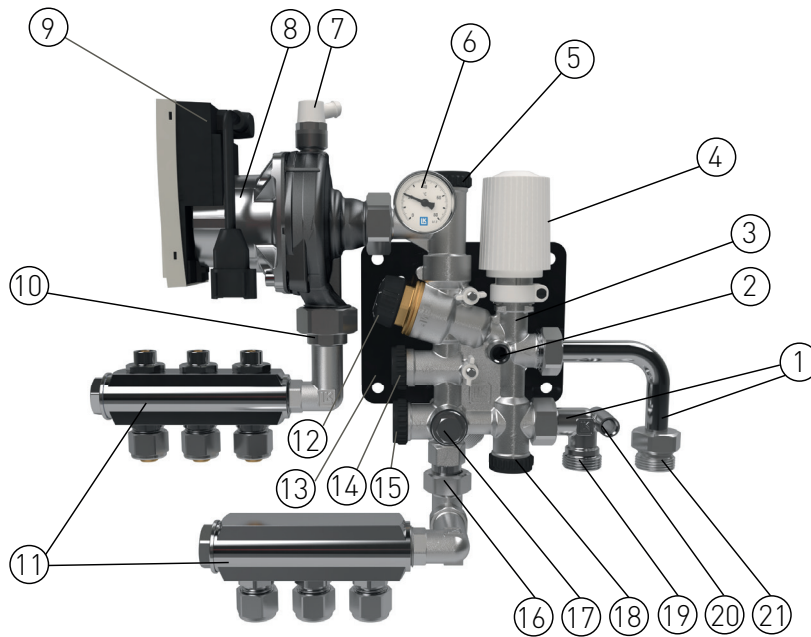

TABLE OF CONTENTS

Design	1
Supplied with product	1
Accessories	1
LK Minishunt M60n, Overview	2
Function and requirements	3
Assembly	3
Installation cabinets	5
Start up	5
Circulationspump	7
Troubleshooting	9
Technical data	9
Flow chart	9
Dimensions drawing	10





LK MINISHUNT M60N, OVERVIEW

1. The LK Elbow Pipes M60n (accessory) for connecting the primary connector when the feed pipe is from below or above. The elbow pipes enables compact assembly.
2. Thermometer pocket to measure the primary supply temperature.
3. LK Valve Housing.
4. Thermostat with capillary tube connected room sensor, length 2 m.
5. Supply valve (V2) for shutting off/ adjusting feed/flow of underfloor heating (dim. 8 mm hex).
6. Thermometer and thermometer pocket for measuring the underfloor heating's supply temperature. A thermometer is supplied and can be placed/moved to the thermometer pocket of your choice.
7. Air bleeding valve with hose nipple. Hose 0.5 m is supplied.
8. Circulation pump, Wilo Para RSB/6-43/SC with automatic speed control.
9. Electrical connection of the circulation pump, see heading Electrical connection of circulation pump.
10. Connector feed underfloor heating 1/2", female.
11. LK Mini Manifold (accessory) for connecting 2, 3 or 4 underfloor heating circuits dim. 8, 12, 16 or 20 mm.
12. Temperature limiter (TEMP). Maximum limit for feed temperature to underfloor heating. Factory setting at 45 °C.
13. Bracket.
14. VF valve (dim. 8 mm hex) only used in installations with low available drive pressure from the primary side of the circulation pump.
15. Return valve (V1) for closing the primary side's return (dim. 8 mm hex).
16. Connector return underfloor heating 1/2" female.
17. Air bleeding/filling valve 1/2" for filling the system during installation. The cover can be used to manoeuvre the valve.
18. Switch between single or twin pipe system. The Minishunt is supplied set for a twin pipe system. You can switch to a single pipe system by screwing out the valve cone (hex 8 mm) until the desired temperature is reached to the radiators.
19. Primary return connection 3/4" EuroCone. Connection couplings for 15 mm CU are supplied.
20. Thermometer pocket to measure the primary return temperature.
21. Primary feed connection 3/4" EuroCone. Connection couplings for 15 mm CU are supplied.



FUNCTION AND REQUIREMENTS

In order for the correct operation of the LK Minishunt M60n and underfloor heating system, the existing heating system must be fitted with a circulation pump and weather dependent supply temperature. The LK Minishunt M60n adapts the heating system temperature to the lower temperature necessary for the underfloor heating system. The heating system must before assembly be flushed through and must not contain any impurities or additives that can damage the product.

ASSEMBLY

The LK Minishunt M60n must be mounted at a higher level than the underfloor heating installation in order to assist air bleeding. When choosing a suitable location for installation, pay attention to any possible structure-borne noise. The shunt group should preferably be placed in a specially designed cabinet in accordance with industry practices, see heading *Installation cabinets*.



NOTE!
The pump shaft must be mounted horizontally.

Pipe connection

The minishunt's primary connection is fitted with an external 3/4" EuroCone thread. Pipe connection to the primary side is made using the enclosed fittings for 15 mm CU. Accessories include connectors for CU12 mm and PEX-/PAL pipes dim. 16x2, 20x2 and 20x2.8. LK Elbow Pipes M60n (accessory) facilitates assembly when the feed pipe is from below or above and needs to be angled into the shunt group. The minishunt's underfloor heating connections have 1/2" females. A single underfloor heating circuit is connected using LK Connection Coupling 1/2" male for pipe dim. 8, 12, 16 or 20 mm directly to the minishunt. For more circuits, the LK Mini Manifold is used to connect 2, 3 or 4 circuits to pipe dim. 8, 12, 16 or 20 mm.

Electrical connection of circulation pump

Electrical connection of the pump must be carried out by a qualified electrician in accordance with applicable regulations. The pump is fitted with a fixed 3-core cable and a Wilo-connector with integrated strain relief. The Wilo-connector replaces the requirements for a 2-pole circuit breaker.

Connect the supply cable L, N, PE to the Wilo-connector according to the following picture sequence. The electrical connection must be fused with Max. 10 A slow blow fuse.

Note!

Before any maintenance/repair work the pump power supply must be disconnected. Motor protection for the circulation pump is not required.

Assembly of electrical connection

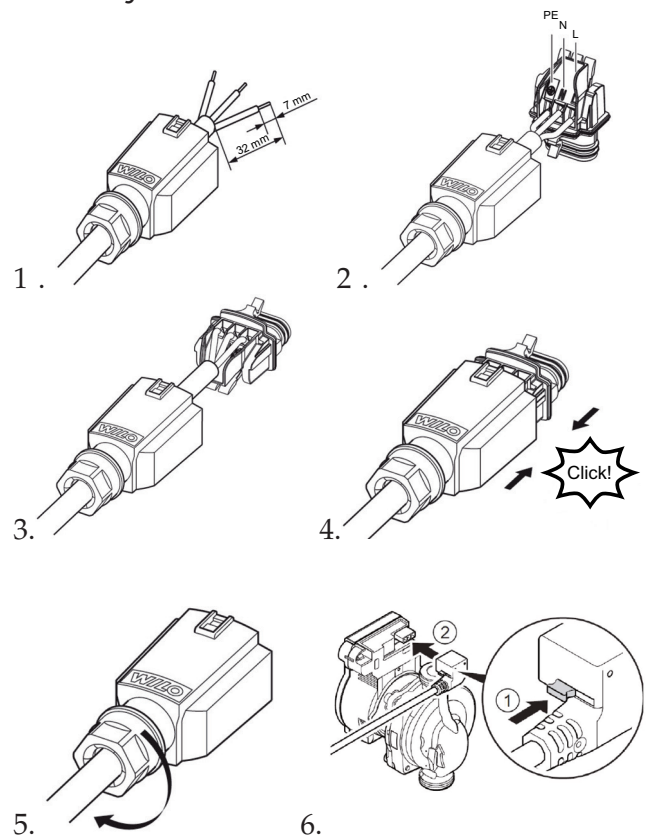

Dismantling electrical connection

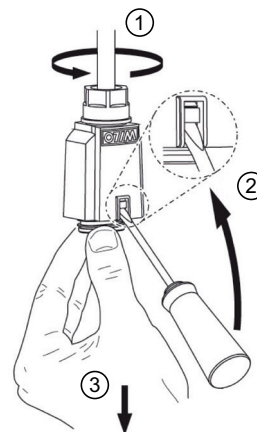

Assembly of supplied thermostat

To install the supplied thermostat, unscrew the hand wheel and assemble the thermostat then.

The capillary tube connected sensor is preferably placed on an interior wall.

1. Unscrew the hand wheel.

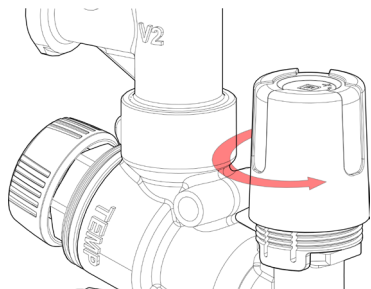

2. Remove the hand wheel.

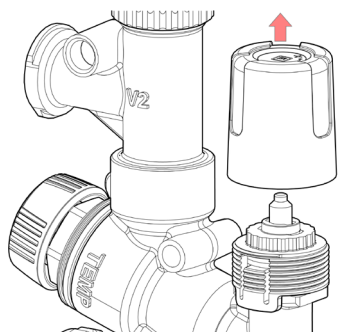

3. Assemble the thermostat.

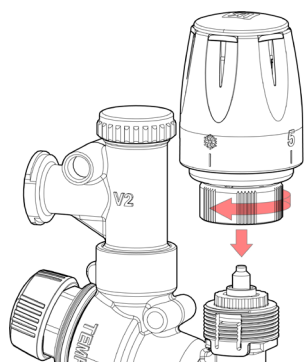

4. Screw on the hand wheel.

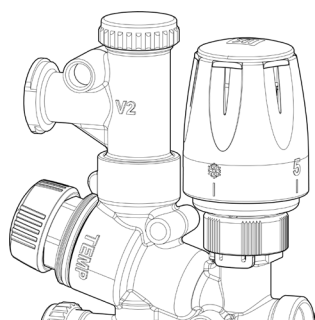

Assembly of LK Actuator

Wireless or wired electronic room control for the LK Minishunt M60n are available as accessories. The enclosed thermostat is then replaced with an electric LK Actuator and is installed according to the picture sequence.

1. Unscrew the hand wheel.

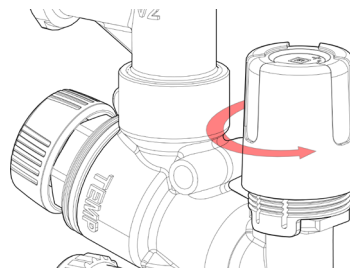

2. Remove the hand wheel.

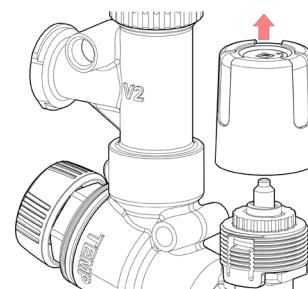

3. Remove the adapter using a screw driver.

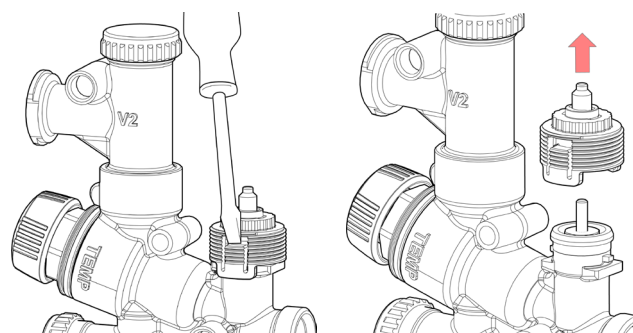

4. Click the adapter that is supplied with actuator into place, and assemble the actuator then.

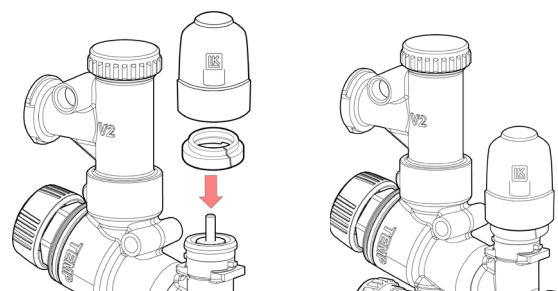

INSTALLATION CABINETS

The installation can be concealed using specially designed cabinets in accordance with industry practices. Cabinets are available for either built-in or wall mounting. The cabinets are made from 1 mm powder coated steel plate and have a sealed base with rubber pipe inlets. The base of the cabinet is fitted with an outlet for leakage indication so that any leakage water can be drained.



LK Minishunt M60n assembled in LK Minishunt Cabinet M60n XL.

Article no.	Name	Intended for
243 53 70	LK Shunt Cabinet M60n	LK Minishunt M60n
243 53 69	LK Shunt Cabinet M60n XL	LK Minishunt M60n with assembled LK Mini Manifold, or LK Heater 350
243 53 67	LK Frame/hatch M60n INB	Built-in LK Shunt Cabinet M60n VT
243 46 80	LK Frame/hatch UFH INB	Built-in LK Shunt Cabinet M60n XL
243 53 68	LK Frame/hatch M60n UTV	Wall mounted LK Shunt Cabinet M60n

243 46 81	LK Frame/hatch UFH UTV	Wall mounted LK Shunt Cabinet M60n XL
188 13 02	LK Base M60n	Wall mounted LK Shunt Cabinet M60n
243 53 72	LK Base M60n XL	Wall mounted LK Shunt Cabinet M60n

START UP

Air bleeding

Flush through the system with hydraulic pressure in order to air bleed it and remove any impurities. The circulation pump should be turned off during this work, follow the process described below:

1. Close against the primary side using the thermostat valve pos. 4. Continue to close the primary side's return by checking that the switch valve from single to twin pipe system pos. 18 is screwed in and that the primary return valve V1 pos. 15 is closed.
2. Close the valve V2 pos. 5.
3. Ensure that the VF valve pos. 14 is fully open.
4. Assemble the hose connection to the filling valve pos. 17.
5. Flush the floor heating side via the filling valve pos. 17 and air bleed/drain through the air bleed valve pos. 7 until the water runs clear.
6. Close the air bleed valve pos. 7 and filling valve pos. 17 and disassemble the hose connection.
7. Open the primary side by resetting the thermostat valve pos. 4 and open the valve V2 pos. 5.
8. Air from the primary side can now be bled out via the air vent pos. 7.
9. Open the return valve V1 pos. 15. If the minishunt is connected to a single pipe radiator system the switch for single or twin pipe system pos. 18 should be adjusted.
10. Start the circulation pump and use the pump's automatic venting routine to remove accumulated air in the pump. See heading *Circulation pump*.



Adjustment

As the LK Minishunt M60n is intended for connection to existing heating systems, the available drive pressure and flow on the primary side are often unknown. Without this information the theoretical adjustment values of the minishunt cannot be calculated. Adjustment should then be carried out as described below.

If the available drive pressure and flow on the primary side are known, the theoretical adjustment for the minishunt can be calculated, refer to the *Project planning and design guidance for LK Underfloor heating*.

1. Carry out air bleeding of the floor heating system and the minishunt, as shown above.
2. Start the circulation pump. Upon start up, use the pump's automatic venting routine to remove accumulated air in the pump. The automatic venting routine starts after 3 seconds and proceeds for 10 min. The venting routine is indicated with a fast flashing green diode light. After completing the venting process, the constant pressure curve that best matches the requirements of the system is chosen, see the *capacity chart*.
3. Set the switch 2/1 pos. 18 for single or twin pipe radiator systems (twin pipe radiator system is factory set at delivery). For single pipe systems the valve is gradually opened until the correct heating capacity and temperature is achieved to the following radiators.
4. Set the primary temperature from the heating source to the minishunt temporarily to approx. 55 °C.
5. Set the temperature limiter TEMP to pos. 12 in accordance with the table below. Normal setting is about 45 °C.
6. Set the thermostat valve pos. 4 in accordance with the table below.
7. Allow the system to stabilise for about 10 min. The feed temperature should now be 35-45 °C.



NOTE!
If the temperature is too low, see Troubleshooting. Note that at start up a system in an unheated concrete slab, can take up to 24 hours before the feed temperature has reached the correct level.



NOTE!
If the temperature is too high, adjust the feed temperature using the temperature limiter pos.12 in accordance with the table below.

8. Finish by resetting the primary temperature from the heat source to normal temperature.

Settings for the temperature limiter (TEMP)

For limiting the feed temperature for underfloor heating.

Settings for the temperature limiter (TEMP)	Max. temperature
0	22 °C
1	25 °C
2	35 °C
3	40 °C
4	45 °C
5	55 °C

Settings for the thermostat with a capillary tube connected sensor

Settings for the thermostat	Room temperature
1	8 °C
2	14 °C
3	20 °C
4	26 °C
5	32 °C

CIRCULATION PUMP

The circulation pump has automatic speed control, which reduces power consumption and gives a quieter operation as the pump adjusts the flow according to the requirements of the system. A cast arrow on the pump housing indicates the direction of the flow. The pump is factory-set to constant pressure pump curve three.



For underfloor heating it is recommended that the pump is set to constant pressure control. Choose the constant pressure curve that best matches the requirements of the system, see *capacity chart*.

Ensure that the pump never runs dry and the system is well vented before use. Use the pump's automatic venting routine at start up.

Setting the pump function selector

The round green push button is used to configure the pump settings. The green LED lights indicate which setting is selected.

- Press the round green push button to select constant pressure.
- Then press it again to select the pump curve.
- To unlock or lock the push button, hold it down for eight seconds.
- Hold the round green button down for 3 seconds to start the air venting function.
- For a manual restart, hold the button down for five seconds.

Automatic venting routine

When the floor heating system is filled, flushed and vented the circulation pump can be started. At start up, use the pump's automatic venting routine to remove accumulated air in the pump's rotor chamber.

The automatic venting routine starts after 3 seconds and proceeds for 10 min. The venting routine is indicated with a fast flashing green diode light.

After completing venting, choose the constant pressure curve that best matches the requirements of the system, see capacity chart below. If no choice is made, the pump operation automatically switches to constant pressure with max. capacity.

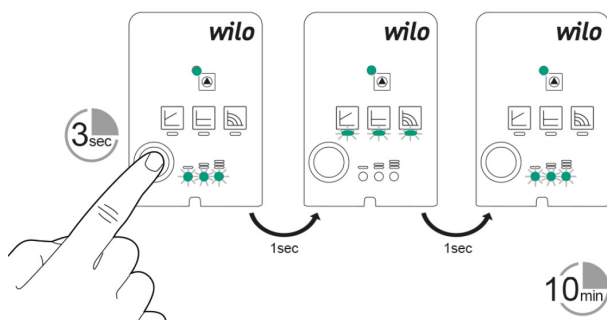

Settings for the automatic venting routine.

Constant pressure curve

For underfloor heating it is recommended that the pump is set to constant pressure control. Choose the constant pressure curve that best matches the requirements of the system, see the *capacity chart*.



The symbol for constant pressure.



Wilo Para RSB/6-43/SC set to constant pressure.

Proportional pressure curve

Proportional pressure setting is normally not used for underfloor heating.



The symbol for proportional pressure.

Capacity chart

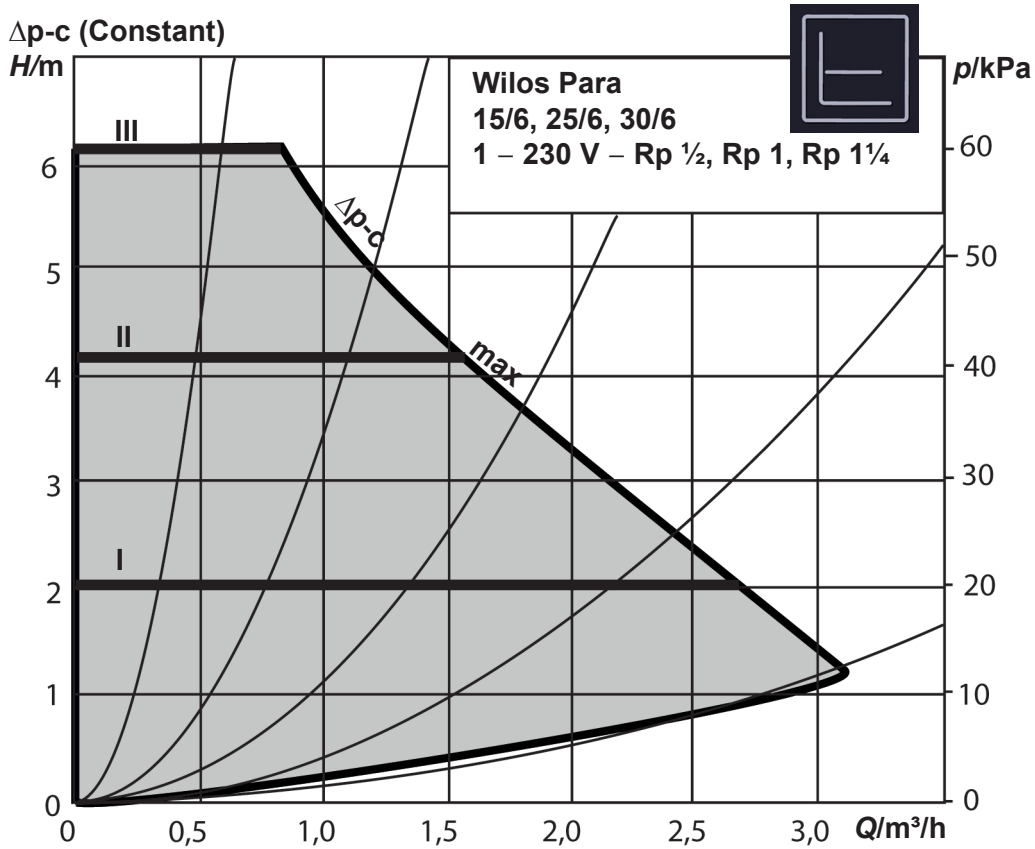

Capacity chart LK Minishunt M60n with Wilo Para RSB/6-43/SC.

TROUBLESHOOTING

The underfloor heating circuit does not get warm

- Check that the Thermostat pos. 4 is set to desired room temperature.
- Check that the shut-off valves pos. 5 (V2) and pos. 15 (V1) are open.
- Check that the setting on the temperature limiter pos. 12 (TEMP) is correct, see table *Settings for the temperature limiter*.
- Check the connection, operation and setting of the circulation pump.

If the above adjustments have been performed and there is still no heat reaching the underfloor heating circuit, this can be an indication of low available drive pressure from the primary side. Begin by checking that the circulation pump of the primary side can be stepped up.

If this does not rectify the situation, the circulation pump of the minishunt can help to “draw” the water from the primary side to the underfloor heating side by gradually closing (clockwise) the VF valve pos. 14 (VF) until the correct temperature has been achieved.

Return temperature of the underfloor heating circuit is too low

- Open the supply valve pos. 5 (V2).
- Increase the speed of the circulation pump using the function selector.

The radiators after the minishunt do not get warm for single pipe radiator systems

The LK Minishunt M60n is supplied in the twin pipe design. For the single pipe system, switching will need to be carried out, see heading *Start up and adjustment*.



TECHNICAL DATA

Article number	243 52 15
Max. operating pressure	0.6 MPa
Max. pressure differential in operation.	0.1 MPa
Operational temperature secondary	+12 - +55 °C
Operational temperature primary	Max. 80 °C
Ambient temperature	Max. +60 °C
Circulation pump	Wilo Para RSB/6-43/SC
Voltage	1 phase 230 V AC +10%/-15% 50/60 Hz, PE
Output	Max. 43 W
Current	Max. 0.44 A
Cable protection class	IP X4D
Insulation class	F
Max. valve capacity	Kvs 1.05
Max. valve capacity with self-acting thermostat at the maximum setting. At room temperature approx. 20 °C.	Kv 0.9
Approved pump	CE, EC Low Voltage Directive (2006/95/ EC) incl. additions

FLOW DIAGRAM

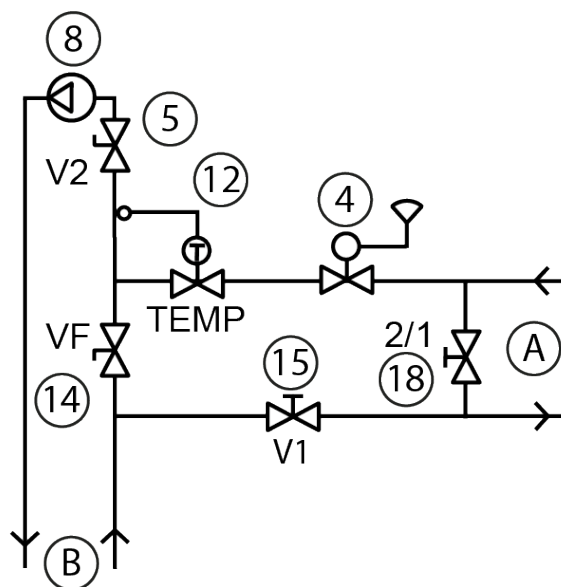

- A. Primary side with main pump.
- B. Secondary side underfloor heating system.
- 18. Switching from twin to single pipe system (2/1).
- 4. Control valve with thermostat and room sensor.
- 15. Isolation valve (V1) primary return.
- 12. Temperature limiter (TEMP). Max. limit for feed temperature to underfloor heating.
- 5. Supply valve (V2) for shutting off/adjusting feed/flow of underfloor heating .
- 8. Circulation pump.
- 14. VF Valve.

DIMENSIONS DRAWING

Right

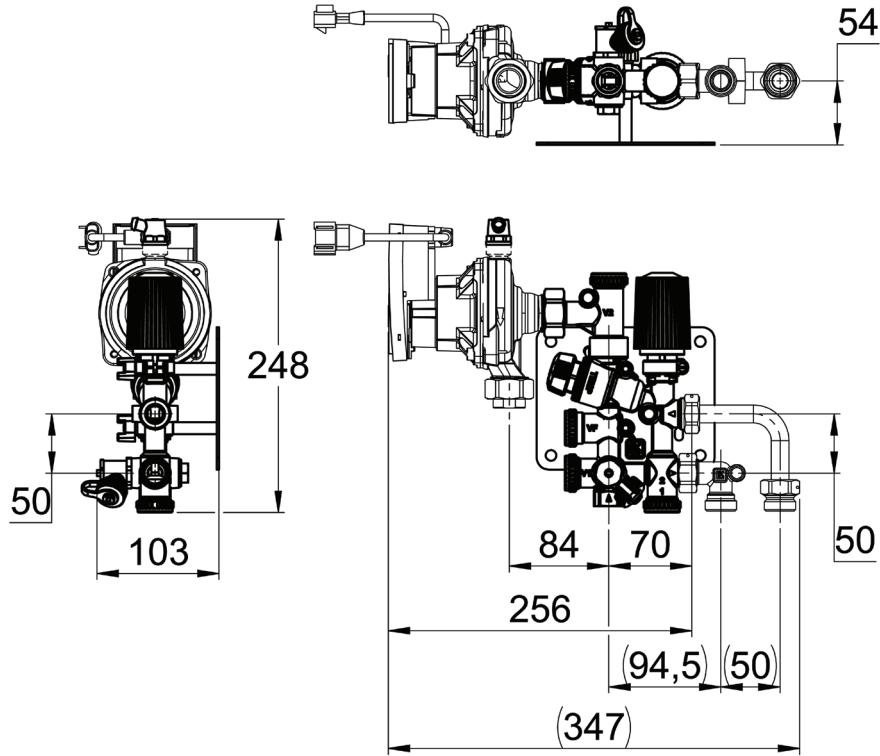

Left

